

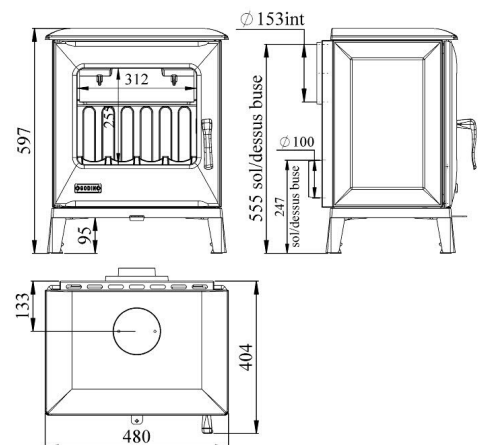

Designed to be elegantly simple, the Mini Cube offers a timeless design, with a splendid view of the fire. The super-efficient Mini Cube, is a compact but big on performance, suitable for any room setting, be it classic dwelling or contemporary styled apartment.

FEATURES & BENEFITS:

- Compact modern design
- Large view of fire
- Heat output up to 120sq.m
- Weight 92kg
- Fuel: wood burning, logs up to 33cm
- Flue connection: from the front or back
- Flue size 150mm
- Cast iron airway system



GODIN MINI CUBE STANDARD INSTALLATION

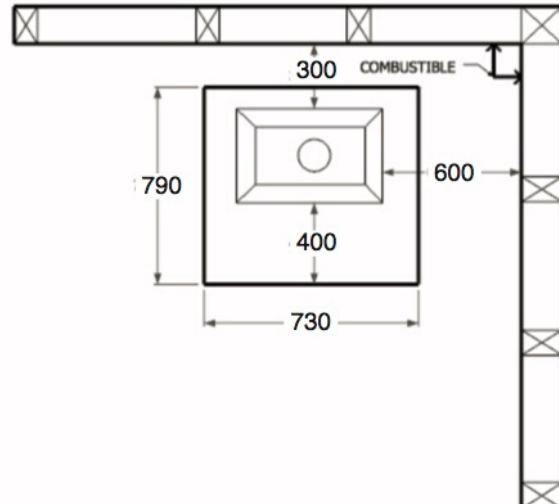
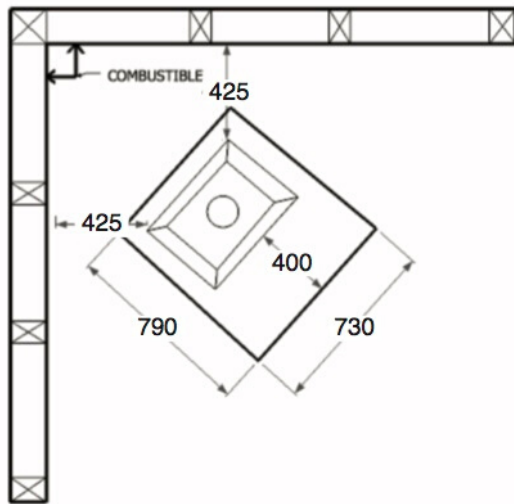
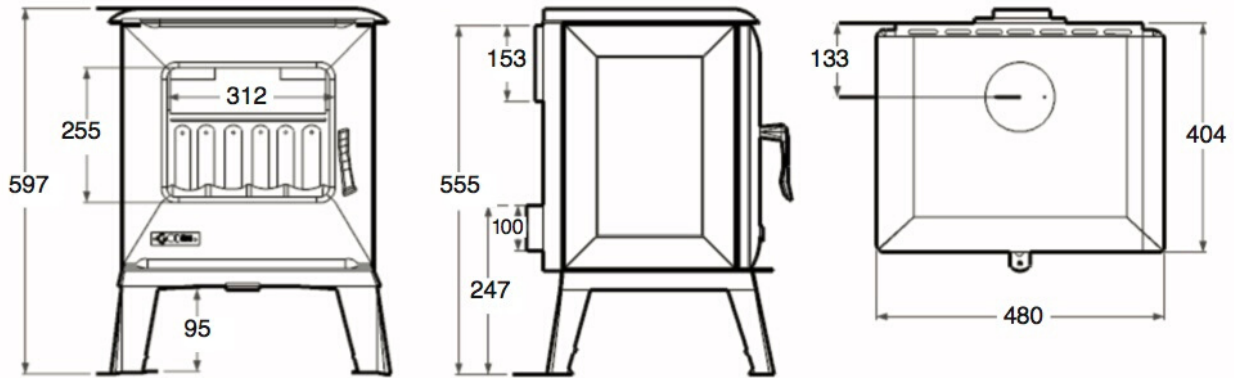

HEATER DIMENSIONS

Height = 597mm
 Width = 480mm
 Depth = 404mm
 Weight = 92kg

HEARTH REQUIREMENTS

Minimum Width = 730mm
 Minimum Depth = 790mm
 From door to front of hearth = 400mm
 Hearth thickness = 20mm

DATA SPECIFICATION

Heating Capacity = 5kw
 Flue Type - 6" /150mm Triple skin flue
 Report Number: ASFT 17084

CLEARANCE FROM NON COMBUSTIBLE MATERIAL

Rear = 100mm Side = 100mm Corner = 100mm

CLEARANCES FROM COMBUSTIBLE MATERIAL

Rear = 300mm Side = 600mm Corner = 425mm

**CHEMINÉES
 PHILIPPE
 AUSTRALIA**

430 Johnston St., Abbotsford, Victoria 3067 Phone: 03 9417 3315
 e-mail: sales@wignells.com.au www.chemphilaust.com.au

IMPORTANT:

Appliance and Flue kit to be strictly installed in accordance to AS/NZS 2918:2001 and the appropriate requirements of the relevant codes. Installer to be a qualified licensed person.